



Wallace Mighty-Mite Crane

For less demanding applications, Wallace offers Mighty-Mite Cranes with 1/4 and 1/2 ton capacities. They are ideal for home/automotive, office and light industrial use. Unlike most workstations, Mighty-Mite stands on its own frame. In addition to making simple height and span adjustments, you have the flexibility to straddle your work area allowing even more freedom of movement. Engineered with the same standard of excellence built into every Wallace Crane, the Mighty-Mite is an all steel lightweight portable design. These cranes are mounted on protective rubber pads however 6" flat tread casters are available. Available accessories include manual or powered trolleys and hoists and optional track mounting with V-groove casters. Click on the accessories tab for more information.

[Mighty Mite Assembly Instructions](#)

Product Features

- I-beam spans from 8' - 15'
- Adjustable span allows inboard or outboard bracing
- Adjustable span allows cantilever configuration overhang limited to 25% of the I-beam length
- Self Aligning I-beam - Exclusive Wallace I-beam support system aligns off-center loads to avoid crane and trolley distortion
 - I-beam support system slides along the I-beam enabling leg spacing adjustments and cantilever configurations
- Adjustable legs permit crane height adjustment at 6" increments
 - Raise height to go over equipment, material, etc...
 - Lower height to go under low ceilings, doorways, etc...
- Fixed caster tread
- Durable construction - 2x2 steel tubing-lightweight portable design
- Stands on own frame with protective rubber pads - optional casters are available
 - Optional casters equipped with 4 position swivel lock - when locked 90 degrees with each other, they position crane more firmly than a brake
 - Lock "lead" casters and unlock trailing casters to easily move and steer crane
 - Alternate steel V-grooved casters are available for use on angle iron track
- Completely portable - Stress-proof steel pins with locking rings provide quick assembly and disassembly
 - Ideal as a workstation for automotive, home, office and light-industrial use

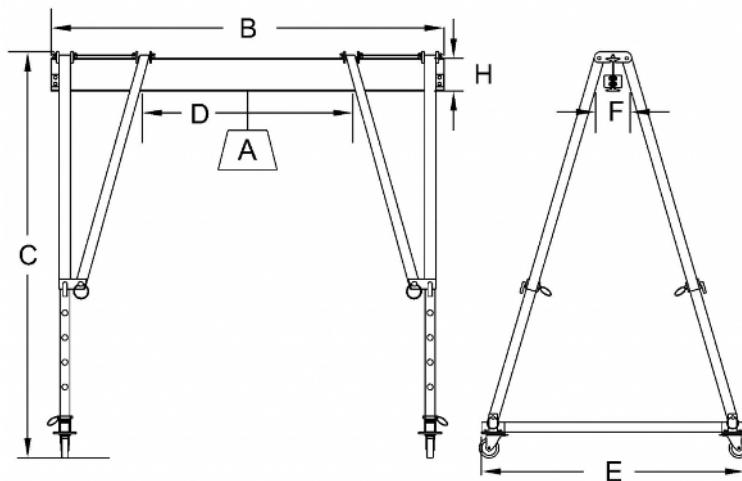

Mighty Mite Dimensional Sketch (Casters Optional) - [Click to enlarge](#)

Crane Sizes and Model Numbers

A	B		C		D	E	F	H	
Capacity (lbs.)	Span (ft.)	Model Number	Overall Height		Clear Span	Caster Frame Spread	Clearance Between Legs	I-Beam Depth	Weight (lbs.)
			max	min					
500	8	5-08M-8	7'11"	5' 3"	5'2"	5'0"	11"	4"	303
		5-10M-8	9'11"	6'2"	5'2"	6'0"	11"	4"	337
		5-12M-8	12'0"	8'1"	5'2"	6'9"	11"	4"	368
	10	5-08M-10	7'11"	5'3"	7'2"	5'0"	11"	4"	319
		5-10M-10	9'11"	6'2"	7'2"	6'0"	11"	4"	353
		5-12M-10	12'0"	8'1"	7'2"	6'9"	11"	4"	384
	12'	5-08M-12	7'11"	5'3"	9'2"	5'0"	11"	4"	335
		5-10M-12	9'11"	6'2"	9'2"	6'0"	11"	4"	369
		5-10M-12	12'0"	8'1"	9'2"	6'9"	11"	4"	400
1000	8'	10-08M-8	7'11"	5'3"	5'0"	5'0"	8"	6"	349
		10-10M-8	9'11"	6'2"	4'9"	6'0"	8"	6"	383
		10-12M-8	12'0"	8'1"	5'3"	6'9"	1"	6"	414
	10'	10-08M-10	7'11"	5'3"	7'0"	5'0"	8"	6"	374
		10-10M-10	9'11"	6'2"	6'9"	6'0"	8"	6"	408
		10-12M-10	12'0"	8'1"	7'3"	6'9"	1"	6"	439
	12'	10-08M-12	7'11"	5'3"	9'0"	5'0"	8"	6"	399
		10-10M-12	9'11"	6'2"	8'9"	6'0"	8"	6"	433
		10-12M-12	12'0"	8'1"	9'3"	6'9"	1"	6"	464
	15'	10-08M-15	7'11"	5'3"	12'0"	5'0"	8"	6"	437
		10-10M-15	9'11"	6'2"	11'9"	6'0"	8"	6"	471
		10-12M-15	12'0"	8'1"	12'3"	6'9"	1"	6"	502

Above cranes mounted on protective rubber pads. Durable flat-tread or V-grooved casters also available.

Note: I-Beams may be cut to custom lengths at no additional charge

Caster Adder: Carton 127-00NB 6" Casters

- When placing order add "C" to end of crane model number
- Add 30 lbs. to Shipping Weight
- Add 7-3/8" to Overall Height Dimensions

Carton 116-000 6" V-Groove Casters

- When placing order add "V" to beginning of crane model number
- Add 48 lbs. to Shipping Weight
- Add 7-1/4" to Overall Height Dimensions without Track
- Add 7-7/8" to Overall Height Dimensions with Wallace Track