



Wallace Tri-Adjustable Gantries

Round Tube Assembly Instructions

For any additional information, Please call 1-800-553-5438

CAUTIONS

1. Read and understand instructions before using this gantry.
2. Inspect gantry thoroughly before using (see Form 379) for damaged or missing parts.
3. Do not lift more than rated capacity.
4. Center hoist over the load.
5. Do not allow load to swing or to roll against any supporting members.
6. When moving gantry under load, push on the gantry, not the load. Be certain that rolling surface is hard, level, clean and smooth.
7. Do not move gantry over 50 feet per minute (1/2 mph).
8. Not to be used for lifting or supporting humans.

Before You Begin

- Place parts on a flat surface, preferably on cardboard, to keep small parts clean and organized.
- Select a clear area to assemble the Crane. The work envelope should extend five feet beyond twice the leg length (when flat) and the length of the I-beam
- This clear area should be serviced by two overhead hoists or alternate as shown in Form 379. The cranes will raise the I-beam and leg assemblies when required.
- Select tools for fastening the nuts and bolts. You will also need: C-clamps to hold the trolley in place while the crane is assembled.

Before Placing the Gantry Under Load

- A. Make certain all hardware is securely attached and all locking pins are in place.
- B. Give the enclosed "Operating and Safety Instructions" to the person(s) with responsibility for the safe use of the Gantry.

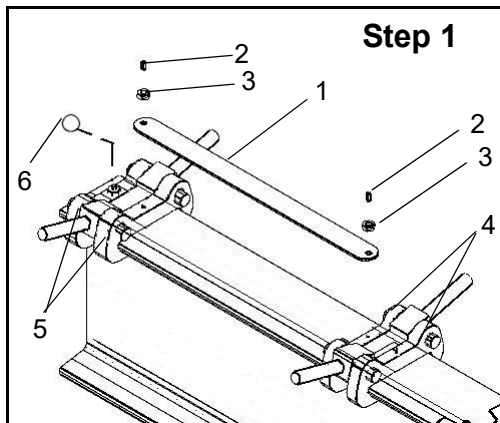

Step 1. Attaching the I-Beam Fittings to the I-Beam

- A. Place I-Beam on suitable supports (barrels, boxes, horses, etc.) so stenciling is right side up.
- B. Slide leg brace bracket assembly [assembly with narrow brackets] (4)-on the I-Beam, followed by the main leg bracket assembly [assembly with thick brackets] (5)-to position on I-Beam for desired span.
- C. Remove set screws (2) with nuts (3) from leg brace bracket (4) and main leg bracket (5) using an allen wrench.
- D. Remove spacer bar (1) from leg brace carton and attach to main leg bracket (5) and leg brace bracket (4) using set screws (2) and nuts (3) previously removed.
NOTE: Do not tighten set screws to I-Beam until after installing main legs (Step No. 4) and brace legs (Step No. 5).
- E. Install locking ring (6) in hole on top flange of I-Beam.
- F. Repeat at other end of I-Beam.

Step 2. Attaching the Trolley and Trolley Stops

- A. Place trolley (if one is to be used) on the I-Beam.
NOTE: Refer to trolley instructions and adjust width, if necessary, to fit the I-Beam of your gantry.
- B. Lock trolley in center of I-Beam using "C" clamps on bottom flange of I-Beam.
- C. Install two trolley stop angles (1) at end of I-Beam using bolts (2) lock washers (3) and hex nuts (4).
- D. Repeat at other end of I-Beam.

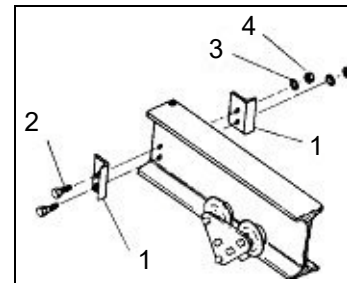

Step 2

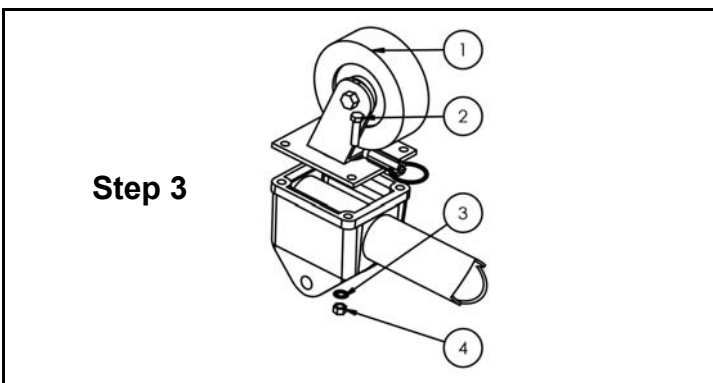

Step 3

Step 3. Attaching the Casters to the Caster Frame Assemblies

- A. Attach casters (1) and swivel locks to the caster frames as shown, using cap screws (2) lock washers (3) and hex nuts (4) provided.



Step 4. Attaching the Main Legs to the I-beam

- A. Attach a main leg (1) to a main leg swivel pin assembly (2) and secure using locking ring (3). Assemble so that the handle of the load pin (4) is up when the leg is horizontal.
- B. Attach the other main legs as right.

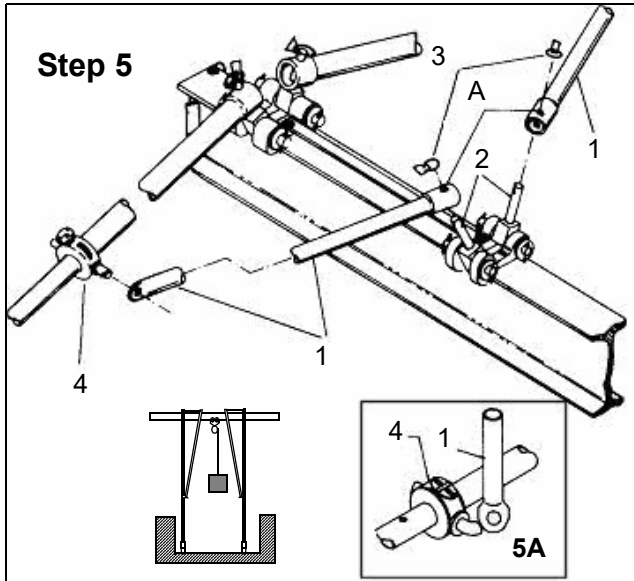
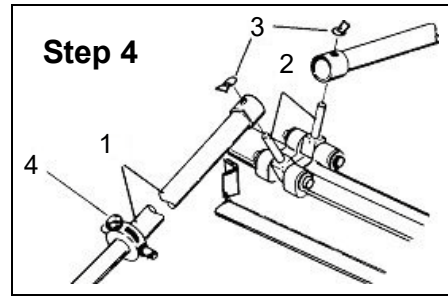

Step 5. Attaching the Brace Legs (Inboard Bracing)

- A. As in detail 5A, attach a brace leg (1) to protrusion of main leg center casting (4). Hold brace leg with flattened end (label on brace leg opposite curved pin) perpendicular to main leg as shown above. Place brace leg hole on curved pin and rotate brace leg over curved pin.
- B. Lower and attach top of brace leg (1) to the leg brace swivel pin assembly (2) in the hole on the brace leg collar marked (A) in illustration left and secure with locking ring (3).
- C. Attach the other brace legs as left.
- D. Tighten set screws in leg brace brackets and main leg brackets to I-Beam.
- E. Secure the four set screws with nuts by tightening the 3/8" nuts.
- F. Raise the I-Beam until the angle between the main legs and the beam is approximately 30°.

Step 6. Attaching the Brace Legs for Outboard Bracing, (Optional) This can be an advantage when the space at the casters is closer than the length of the I-Beam

- A. Slide the main leg bracket assembly-assembly with thick brackets (1)-on the I-Beam, followed by the leg brace bracket assembly-assembly with narrow brackets (2)-to position on I-Beam for desired span.
- B. Follow Step Numbers 1C and 1D.
- C. Insert locking ring (3) through hole in end of I-Beam to ensure the assembly never slides beyond the end of the I-Beam.
- D. Attach the main legs as in Step No. 4.
- E. Attach the brace legs as in Step No. 5.

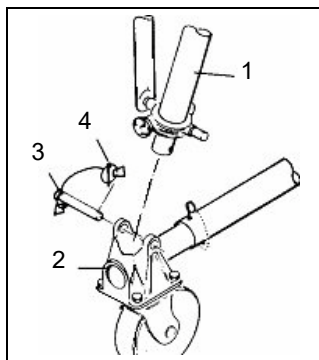
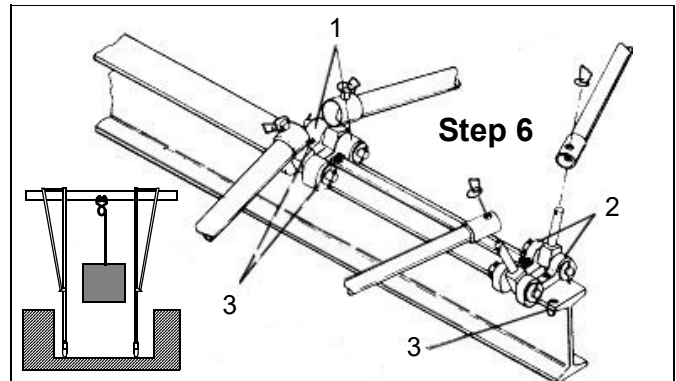

Step 7. Attaching the Caster Frames to the Main Legs

- A. Attach Main legs (1) to Caster Frame Castings (2) with Lower Main Leg Pin Assemblies (3) and secure with Locking Pins.

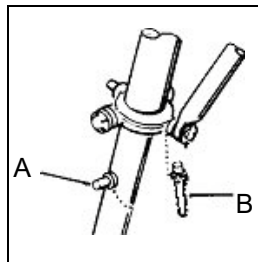

Step 8. Four Safety Stop Pins

- A. If the Gantry is to be left at minimum height, attach the Safety Stop Pins to the Brace Legs (as shown left, so they will be available for future use.
- B. If Gantry is to be assembled with Legs extended, install and secure Safety Stop Pin in the hole below the Load Pin casting

CAUTION: Secure trolley in the center of the I-Beam, with suitable means, such as heavy clamps, when raising or lowering the assembly. Failure to do so may result in injury or death.



Wallace Tri-Adjustable Gantry Cranes

Operating, Adjustment, and Inspection Instructions

Read, Understand, and Comply with all instructions supplied with this crane. Also, pay attention to the equipment used with this crane such as hoists, trolleys, power drives (if applicable), etc.

Read, Understand, and Comply with the requirements of OSHA (Occupational Safety, and Health Administration) 1910.179

Assembly and Safety Instructions

Inspect Crane Before Moving and/Or Each Day's Use

- Center Load under I-Beam before lifting
- When moving crane under load, position load at center of the I-Beam.
- Use crane at lowest height possible, to lower center of gravity.
- DO NOT lift or support humans.
- DO NOT allow load to swing or roll against any supporting members.
- DO NOT TOW or Pull Crane.
- DO NOT OVERLOAD CRANE.
 - A. Do not lift loads that are heavier than the rated capacity of the crane.
 - B. Make certain the load is free to be lifted.

Positioning of Crane to Handle Loads

DO

- Keep Load Hook of Hoist in the Shaded Safe Zone.

Allowable

The hinged suspension of the I-Beam allows 7.5° movement to either side to allow for slight off-center loading.

Under normal conditions (for example, the casters positioned at right angles to the I-Beam and the crane is free to roll), the crane will move to self-align over the load.

DO NOT!

- The crane may "topple" if the hook is not kept in the shaded safe load zone and the crane is not free to align over the load.
- Lifting off centerline at one end of the crane is dangerous! Up to 90% of the load can be carried by ONE leg. Even though rated capacity is not exceeded, the result can be a 90% overload and the trolley is improperly loaded

Positioning of Casters

- To secure crane position while lifting load, lock diagonally opposite casters as shown.
- To utilize maximum crane strength, lock casters as shown.
- To move crane and/or load perpendicular to I-beam, lock casters as shown or allow casters to pivot freely.
- To move crane and/or load parallel to I-beam, lock casters as shown or allow casters to pivot freely.

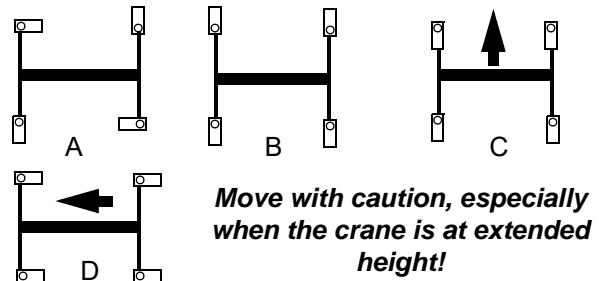

Pull out and turn pin as necessary to provide a locked or unlocked caster position, then release pin.

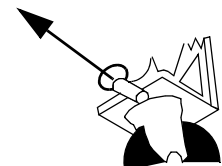

Wallace Tri-Adjustable Gantry Cranes

Height Adjustment Procedure

1. Lock casters parallel to the I-beam to prevent the main support legs from moving during adjustment.
2. Locate safety stop pins, as required during adjustment. See instructions on Tag #1337 attached to safety stop pin.
3. Raise crane slightly to clear notches in load bolts, pull out load bolts and rotate 90° to "lock-out" position.
4. When within approximately 3" of desired height, rotate load bolts to "unlocked" position.
5. Continue height adjustment (up or down), to allow load bolts to align with and engage next hole.
6. Visually check to insure that all four load bolt caps are FULLY ENGAGED.
7. Insert safety stop pins with Tag #1337 into first hole below upper main legs and secure in place with locking pins. When crane is at minimum height, attach to brace leg, as shown in Illustration "A".
8. Remove crane supports, trolley and hoist stops, and adjust caster positions as required.

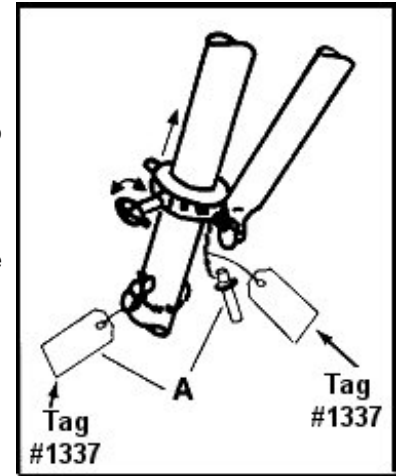

Caster Frame Adjustment Procedure

1. When I-beam is supported externally, raise I-beam slightly to take the weight off the caster frame spread adjustment pin. Remove pin. Raise or lower I-beam to decrease/increase caster frame spread. Replace spread adjustment pins. Secure in place using locking pins.

OR

2. a) Turn and lock casters perpendicular to the I-beam and secure trolley and hoist to prevent rolling. b) One jack (right or left) only is used for caster frame spread adjustment. c) Remove the pulley at the bottom of jack and pass end of cable through the pulley slot and extend it to the first hole in main leg above the caster frame using eye bolt provided, reinstall pulley, axle and klik-pins. d) Insert pin assembly and jack into first hole above the caster frame; attach all the locking pins in the pin assembly. e) Using jack winch, take weight off caster frame adjusting pin, then remove pin. f) Adjust spread as required and replace adjusting pins. Secure using locking pins.

OR

3. When lever type winch is used, take weight off spread adjustment pin, then remove pin. Adjust spread as required and replace spread adjustment pins. Secure in place using locking pins.

NOTE Be prepared to control the weight. The caster frame tends to open to maximum spread when the spread adjustment pins are removed.

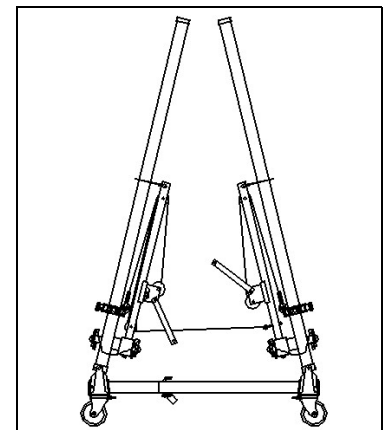

Cantilever Configuration/Adjustment of Distance Between Legs Along Length of I-Beam Procedure

1. Raise one end of I-beam until casters are off the floor.
2. Loosen set screws on top of I-beam hardware.
3. Slide I-beam hardware, with legs attached, on I-beam until the desired amount of cantilever or leg adjustment is achieved.
4. When adjusting for cantilever, DO NOT OVER-ADJUST. Adhere to distances specified in Form 123 (Cantilever Chart provided with the crane) for the amount of cantilever, load and counterweight required.
5. When desired amount of cantilever or leg adjustment is achieved, securely tighten set screws to prevent movement.
6. Repeat above if leg adjustment on opposite end is required.

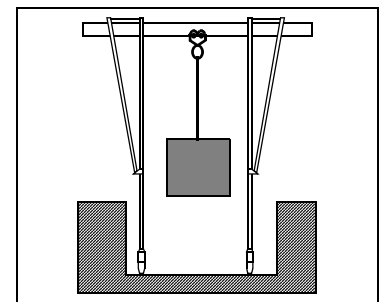

Wallace Cranes, Built-in Safety



Wallace Tri-Adjustable Visual Check Points

To ensure the safe operation of your crane, inspect it for bent, broken, worn, corroded, cracked, or missing parts. A series of vital checkpoints are described and shown below. Check these areas closely to ensure that all pins and fastening hardware are in place and securely attached. Caution Tags are attached to the Locking Rings and Locking Pins in these critical areas to aid in your inspection. **DO NOT USE** the crane if it does not meet these and the relevant ANSI B30.17 inspection requirements.



1. Brace legs are attached to pin assemblies and secured with locking rings. On round tube models (shown above) the flat end of the brace leg is attached to the load bolt casting. Also be sure that load bolt is properly engaged. See number 3.



2. The main legs are attached to the pin assemblies and secured with locking rings. Locking rings at each end of the I-Beam should be in place and secured to ensure the I-Beam Hardware never slides beyond end of I-Beam.

3. The four safety stop pins must be installed and secured with Klik pins in the first hole below the load bolt (see crane image, left). When crane is at minimum height, attach pins to brace leg.

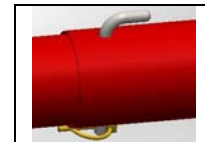

4. The caster frame spread pins should be secured with klik pins.

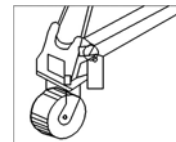

5. Lower main legs are attached to the caster frame casting with pins, secured with a Klik pin. Inspect casters and wheels for damage, such as cracks, bent king pins and freedom of movement. Replace any damaged casters immediately.

Read, Understand, and Comply with the instructions on the Crane and:

- Rated load clearly stenciled on opposite sides of I-beam.
- Form 379 (This Form) attached in convenient location by user.
- Caution label for instructions attached to caster frames.
- Caution label pointing to caster frame adjustment pin.
- Caution labels attached to main legs.
- Caution tag attached to safety stops.
- Caution tag attached to locking pins.

CAUTION AREAS

Make certain that all **CAUTION** labels are in place and legible. Replacements for damaged or missing labels upon request.

Inspect that rated capacity is plainly marked on each side of I-beam. Each hoisting unit shall have its rated load clearly marked and shall be legible from ground or floor.

Inspect safety cables in caster frames for proper attachment, fraying or any damage. Replace damaged cables immediately.



Klik pins must be closed.

Wallace Cranes
71 N Bacton Hill Rd.
Malvern, PA 19355



www.wallacecranes.com
800-553-5438

© 2017 All rights reserved.

Wallace Tri-Adjustable Cranes

General Safety Instructions for Crane Adjustments

- **ADJUSTMENTS** and/or repairs should be made in an area where they will have the least interference with ongoing operations.
- **DO NOT** make adjustments when the crane is under load. If crane is in operation, lower and disconnect the load before making any adjustments.
- **SECURE TROLLEY AND HOIST** to prevent movement during adjustment of crane.
- **EXTEND CASTER FRAMES** to maximum width (last hole) when possible, for greatest stability.
- **SAFETY STOP PINS** should be installed in the first hole below the load bolt on the main legs.
- **DO NOT ADJUST** any one leg (or end) more than one foot above or below the other legs (or end), as it could cause the crane to “topple” and result in injury and/or equipment damage.

Methods of Supporting Crane for Assembly

DO NOT ASSEMBLE OR DISASSEMBLE OR MAKE ANY ADJUSTMENTS TO CRANE
UNTIL the unit is supported by one of the five methods illustrated below.

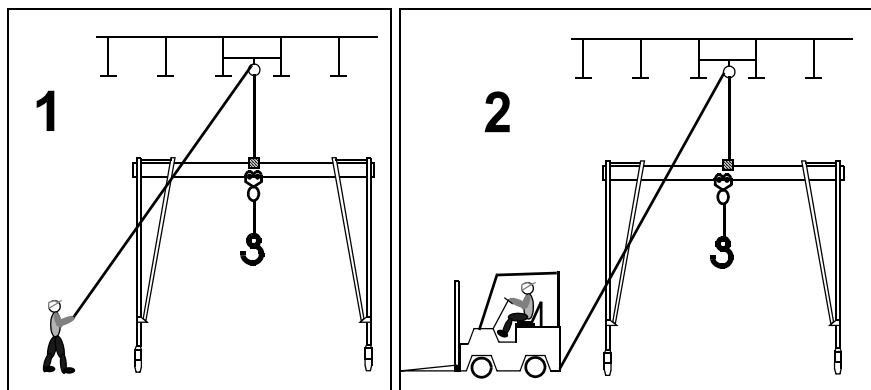

1 Use a Block and Tackle with cable winch with lifting bracket or beam clamp

2 Use a block and tackle with lifting bracket or beam clamp with a suitable truck.

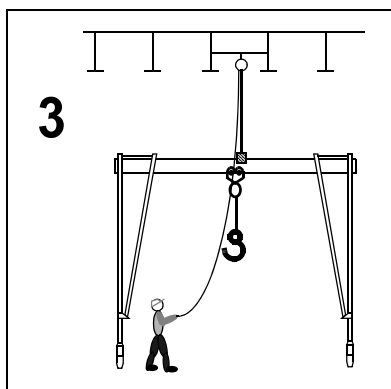

3 Use a hand or electric hoist with a lifting bracket or beam clamp.

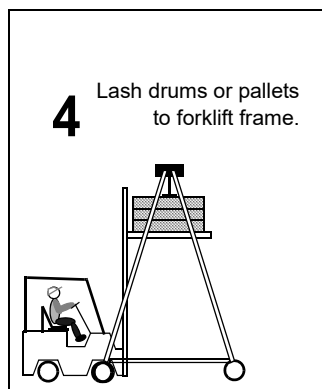

4 Use a forklift truck.

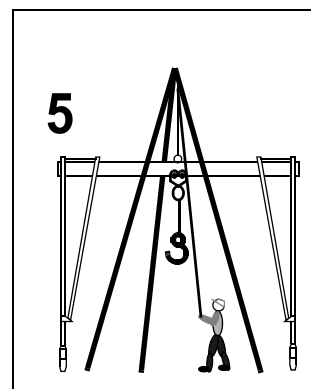

5 Use a tripod and hoist with a lifting bracket or beam clamp.



Wallace Cranes

Safety Tag and Label Locations, Round Tube, Tri-Adjustable

Safety Tag Location

The following sketch shows the location of required safety tags on Wallace Tri-Adjustable Gantry Cranes. All locking pins or pins with a quick release must have a corresponding Tag 1969. Following the schematic below is a complete listing of all text found on all Labels and Tags on the Crane.

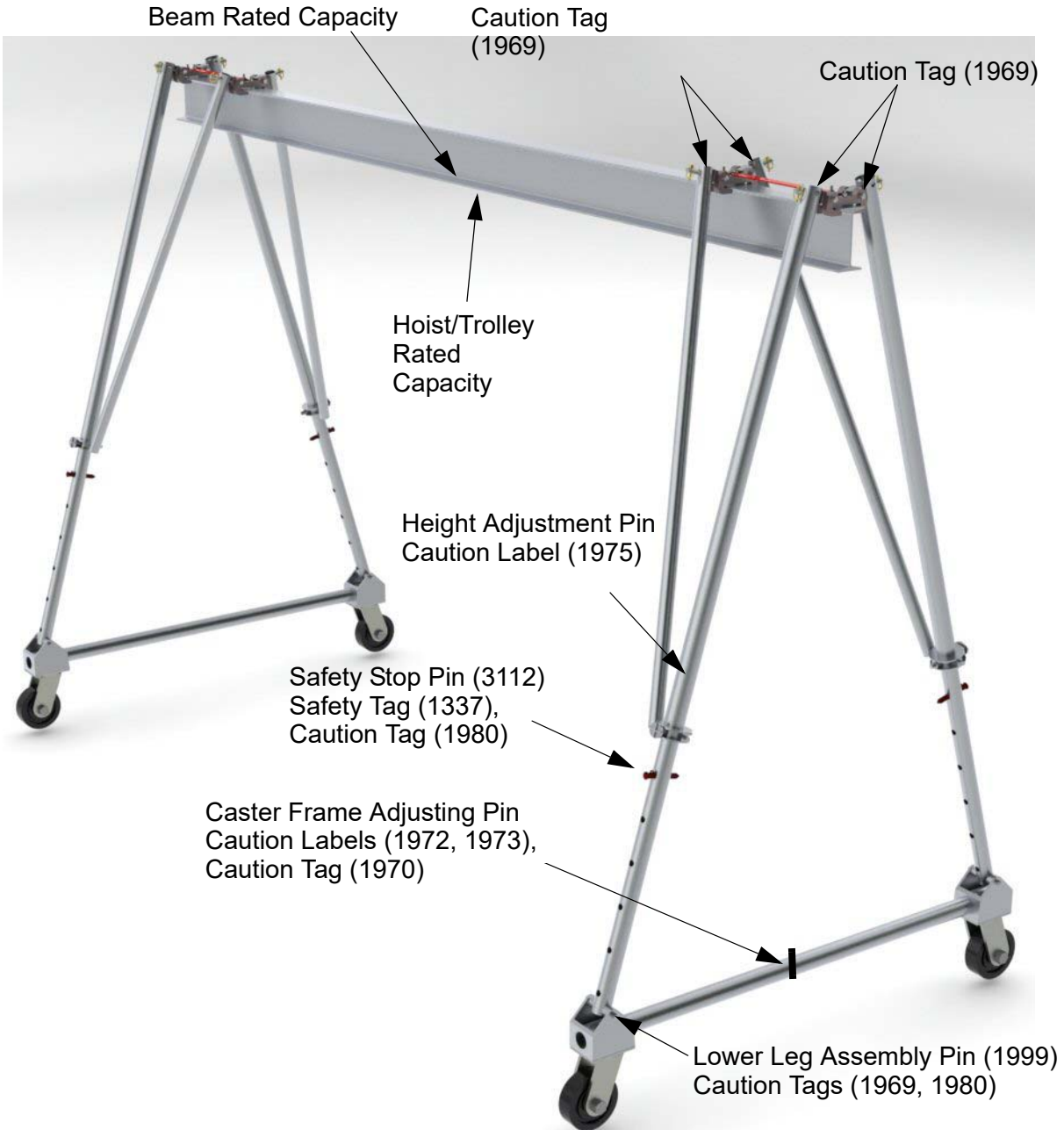

NOTE: Labels are found at identical locations on the left and right sides.



Caution Labels 1973, 1975

1973/R14

CAUTION

1. Read and understand instructions before using this gantry.
2. Inspect gantry thoroughly before using (see Form 379) for damaged or missing parts.
3. Do not lift more than rated capacity.
4. Center hoist over the load.
5. Do not allow load to swing or to roll against any supporting members.
6. When moving gantry under load push on the gantry, not the load. Be certain that rolling surface is hard, level, clean and smooth.
7. Do not move gantry over 50 feet per minute (1/2 mph).
8. Not to be used for lifting or supporting humans.

REQUEST FREE REPLACEMENTS IF THIS OR ANY OTHER GANTRY LABELS OR INSTRUCTIONS ARE DAMAGED OR MISSING.

**WALLACE CRANES
MALVERN, PA 19355
www.wallacecranes.com**

1975/R13

CAUTION

FOLLOW INSTRUCTIONS BELOW BEFORE PULLING THIS LOAD BOLT. GANTRY WILL NOT STAND ON 3 LEGS - INJURY COULD RESULT FROM GANTRY COLLAPSING.

SEE "OPERATING AND SAFETY INSTRUCTIONS" (Form 379) FOR COMPLETE INFORMATION. ADJUSTING HEIGHT WHEN THIS LEG IS USED IN A WALLACE ADJUSTABLE GANTRY:

1. Do not make adjustments when the unit is under load.
2. Secure Trolley and Hoist to prevent rolling to low end of beam.
3. Securely support the I-Beam externally (or use Wallace Gantry Jack).
4. Extend caster frame for greatest stability.
5. Lock casters parallel to I-Beam.
6. Install the Safety Stops (one per leg) before pulling load bolts. They limit downward leg travel - see instructions on tags attached to stops.
7. Raise upper leg slightly to release the load bolt, then pull out and rotate 90° (or pin where applicable) to "lock out" position.
8. After adjusting height, turn back to unlock. Be certain all load bolts are fully engaged.
9. Relocate safety stops with tags.

**WALLACE CRANES
MALVERN, PA 19355
www.wallacecranes.com**

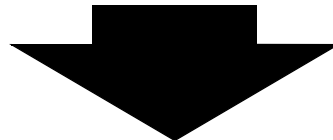

Caution Label 1972, Caution Tags 1969, 1970, 1980

1972/R14



FOLLOW INSTRUCTIONS BELOW BEFORE REMOVING THIS TREAD ADJUSTMENT PIN

SERIOUS INJURY COULD RESULT FROM COLLAPSE OF GANTRY AND/OR MOVEMENT OF LOAD.

1. Do not make adjustments when the gantry is under load.
2. Secure Trolley and Hoist to prevent rolling to low end of I-Beam.
3. Make certain the restraining cable is secured in place (inside or outside of the tubes, depending on model).
4. Securely support the I-Beam externally or:
5. Use Wallace Gantry jack to adjust in accord with instructions on jack and in Form 379.
6. Or use lever type winch or block and tackle, etc., to adjust tread in accord with instructions in Form 379.
7. Remove the tread adjusting pin and adjust as required. Replace the tread adjusting pin and secure with locking pin.

**WALLACE CRANES
MALVERN, PA 19355
www.wallacecranes.com**

1969
R14



DO NOT REMOVE THIS LOCKING PIN GANTRY COULD COLLAPSE -- INJURY CAN RESULT

Only remove to disassemble gantry after I-Beam is securely supported externally. See Mfrs. instructions for assembly/disassembly.

**WALLACE CRANES
MALVERN, PA 19355
www.wallacecranes.com**

Front/Rear identical on Tag 1969

1970
R14



Only remove this locking pin when adjusting caster frame spread. Read instructions on label 1972. After making adjustment, replace this locking pin to secure tread adjustment pin.

**WALLACE CRANES
MALVERN, PA 19355
www.wallacecranes.com**

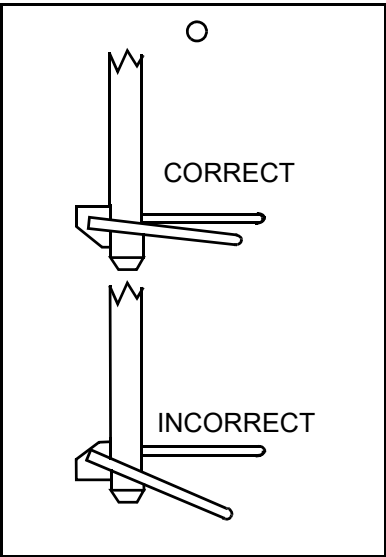

1980
R14



DO NOT REMOVE THIS LOCKING PIN GANTRY COULD COLLAPSE -- INJURY CAN RESULT

Only remove to disassemble gantry after I-Beam is securely supported externally. See Mfrs. Instructions for assembly/disassembly.

**WALLACE CRANES
MALVERN, PA 19355
www.wallacecranes.com**

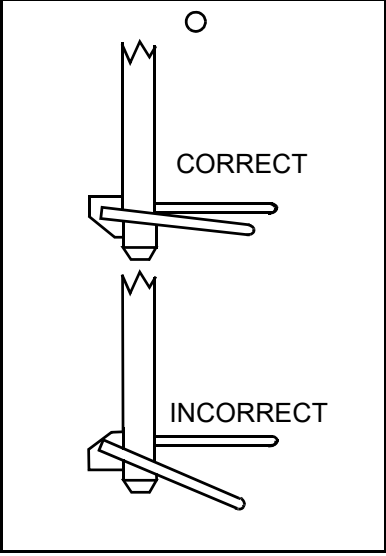

Tag 1337

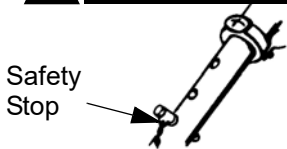
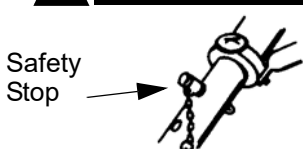
<p>1337 R14</p> <p>! CAUTION</p>  <p>Safety Stop</p> <p><u>LOWERING GANTRY</u> Place safety stop 3 holes or fewer below upper leg. Lower leg 2 holes maximum. Repeat as required. <u>See other side for raising.</u></p> <p>WALLACE CRANES MALVERN, PA 19355 www.wallacecranes.com</p>	<p>! CAUTION</p>  <p>Safety Stop</p> <p><u>RAISING GANTRY</u> Place safety stop 1 hole below upper leg casting. Raise leg 2 holes maximum. Repeat as required. <u>See other side for lowering.</u></p> <p>WALLACE CRANES MALVERN, PA 19355 www.wallacecranes.com</p>
--	--

Front of Tag

Rear of Tag





Wallace Crane Safety

Safe Use and Operation Instructions & Inspection Checklist

Read, Understand, and Comply with all instructions supplied with this crane. Also, pay attention to the equipment used with this crane such as hoists, trolleys, power drives (if applicable), etc. Read, Understand, and Comply with the requirements of OSHA (Occupational Safety, and Health Administration) 1910.179

To ensure the safe operation of your Gantry, frequently inspect it for BENT, BROKEN, CORRODED, CRACKED, DAMAGED, or MISSING parts. DO NOT USE GANTRY if it does not meet inspection requirements. Please contact Wallace for replacements for any non-functional components.

DO NOT:

- Overload Gantry
- Lift loads greater than the rated capacity.
- Make any adjustments when the Gantry is under load. If necessary to adjust the Gantry, first lower and disconnect the load.
- Lift or support humans.
- Allow the load to swing or roll against any supporting members.
- Tow or Pull Gantry.

DO:

- Make certain the load is not attached to the floor.
- Remove any obstacles that may impede lifting.
- Make adjustments and/or repairs in an area where these operations will have the least impact on the normal operating environment.
- Secure the trolley and hoist to prevent movement during adjustment of the Gantry.
- Position the load at the center of the I-Beam when moving the Gantry under load.
- Use the Gantry at the lowest height possible.

Disclaimer

Please note these instructions were derived from company proprietary materials and (3) source documents including **ANSI B30.17**, **CMAA Specification #74, Revised 1987**, and **OSHA 1910.179**. As excerpts, the short form Wallace documents are intended to serve as general guidelines and are not to be considered the sole source when performing routine maintenance and inspection tasks.

Inspection Checklist on Other Side



Inspection Checklists

Excerpted from ANSI B30.17 –1980

Chapter 17-2 Inspection, Testing, and Maintenance.

Frequent Inspection

- a. Normal service, monthly.
- b. Heavy service, weekly to monthly.
- c. Severe service, daily to weekly.

Periodic Inspection

- a. Normal service, yearly – done in place.
- b. Heavy service, yearly – done in place unless disassembly is indicated (*if you completely disassemble, you must retest*) emphasis WCC.
- c. Severe Service, quarterly – done in place.
- d. Recommended interval as suggested by manufacturer.

Frequent Inspection Checklist

Any deficiencies as listed below shall be examined to determine if they constitute a hazard.

- All functional operating mechanisms for mis-adjustment interfering with proper operations.
- All limit switches should be checked without a load on the hook.
- Lines, tanks, valves, pumps and other parts of the pneumatic system for leakage.
- Hoists as specified in ANSI B30.16-1973

Periodic Inspection Checklist

The crane should be examined to determine if any of the following defects exists. DO NOT USE if any damage is found.

- Deformed, cracked, or corroded structural members
- Loose bolts or rivets.
- Cracked or worn sheaves and drums.
- Worn, cracked or distorted parts, such as pins, bearings, wheels, shafts, gears, rollers, locking and clamping devices, bumpers, switch baffles, interlock bolts, and trolley stops.
- Excessive wear on brake system parts.
- Excessive wear of chain drive sprockets and excessive chain stretch.

