



# Wallace Fixed Height Gantry Cranes

## Thrifty Assembly Instructions

Read, Understand, and Comply with all instructions supplied with this crane. Also, pay attention to the equipment used with this crane such as hoists, trolleys, power drives (if applicable), etc. Read, Understand, and Comply with the requirements of OSHA (Occupational Safety, and Health Administration) 1910.179

### Parts List

#### Item Description

- |    |                       |
|----|-----------------------|
| 1  | I-Beam                |
| 2  | End Frame             |
| 3  | Caster                |
| 4  | Cap Screw -- Caster   |
| 5  | Lock Washer -- Caster |
| 6  | Hex Nut -- Caster     |
| 7  | Cap Screw             |
| 8  | Bevel Washer          |
| 9  | Lock Washer           |
| 10 | Hex Nut               |

When ordering parts, specify Item Number, Description, and Model Number of your Gantry Crane.

### CAUTION AREAS

Make sure that all CAUTION labels and safety tags are in place and legible. Inspect that rated capacity is plainly marked on each side of I-Beam. Each hoisting unit shall have its rated load clearly marked and legible from ground or floor.

#### Before you Begin

- Clear an open area at least as large as 2 X the frame length and wider than the beam.
- Get a crane or lifting device capable of lifting the entire weight of the completed crane.
- Assemble a work crew of no less than three. One will operate the lifting crane and the others perform the assembly. You may need more to lift the higher capacity legs.

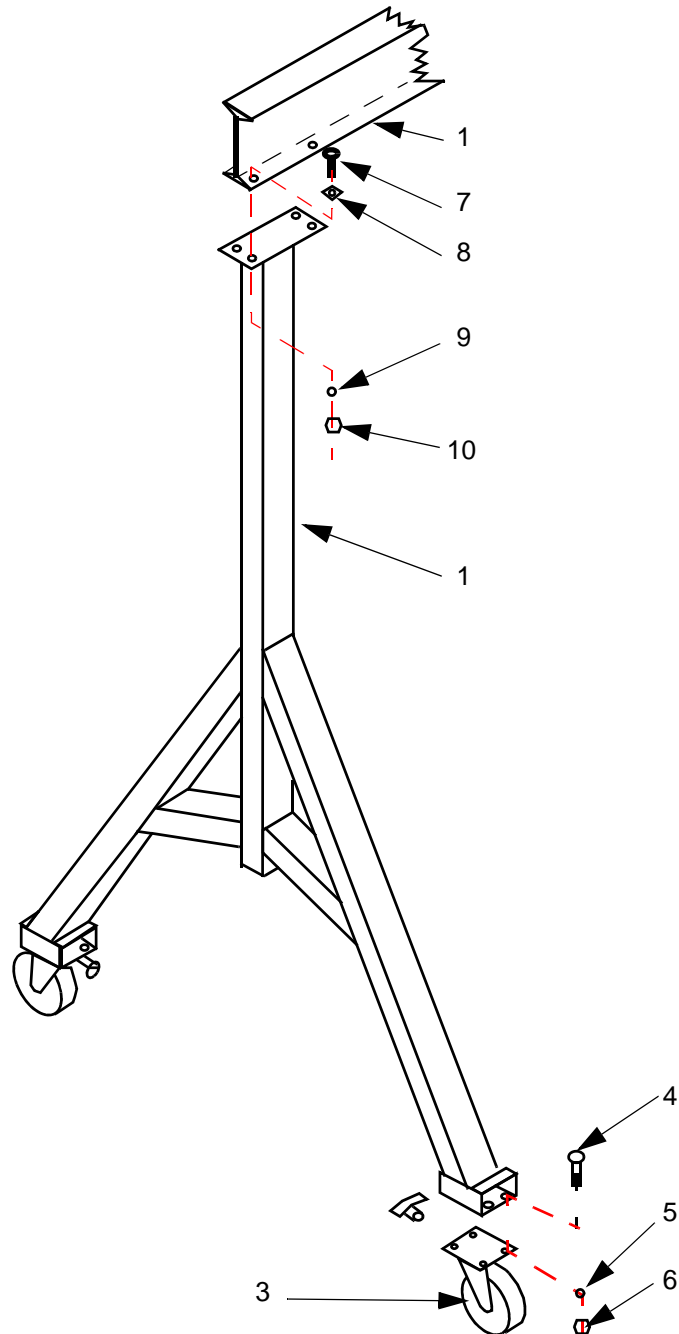

## Assembly Instructions

For assembly, select an area with a safe lifting means. For easiest and safest assembly, use an area with two overhead hoists (for example an overhead crane) to raise the I beam when required.

### Step 1. Installing the Trolley (Sold Separately)

- Raise the I-Beam, using a safe lifting means, so stencilling is right-side up.
- Install Trolley from either end of the beam on the lower flange of the beam
- Lock Trolley in center of beam using C-Clamps on the bottom flange of the beam.

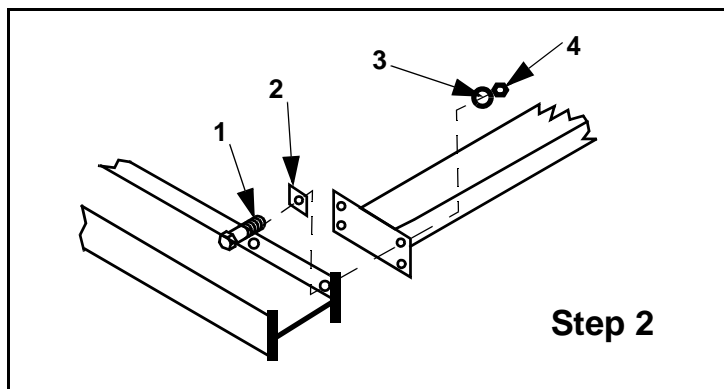

### Step 2. Attaching the Post to the I-Beam

- Place adapter plate end of frames on suitable supports (barrels, boxes, horses, etc., so that frames are at the applicable distance apart for each other for easy attachment to beam.  
**NOTE** Frames are to be on edge so that one caster plate is directly above the other.
- Place I-Beam web side down on suitable supports to align bottom flange of I-Beam with adapter p-plates of Frame.  
**NOTE** If unit is equipped with adjust-a-span kit, disregard 2C through 2D and refer to adjust-a-span kit instructions.
- Insert cap screws (1) with bevel washers (2) through flange of I-Beam and adapter plates of the posts.
- Insert lock washers (3) and hex nuts (4) on cap screws (1) and tighten cap screws and hex nuts.
- Raise the I-Beam lift frames using a safe lifting means.

### Step 3. Attaching Casters to the Frames

- Raise the I-Beam, so that the frames are sufficiently above the floor for installation of the casters.
- Attach casters (1) and swivel locks (2) to the frame as shown, using cap screw (3), lock washer (4) and hex nut (5) provided.  
**NOTE** Some models have swivel locks welded to caster rigs.
- Lower gantry so that casters are on floor and remove lifting means. (  
**NOTE** For track-mounted gantries - if frames/casters do not properly align with track, slightly loosen bolts that attach posts to frames and re-tighten.

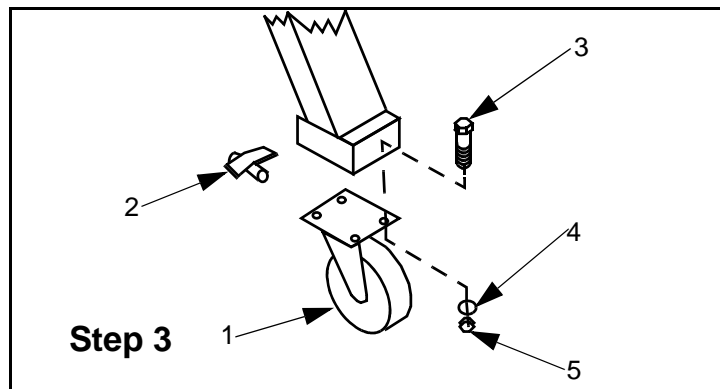

### Step 4. Remove C-Clamps on Bottom Flange of Beam (to release Trolley)

**ALL BOLTS SHOULD BE TIGHTENED TO 25 FOOT POUNDS  
25 FOOT POUNDS = 300 INCH POUNDS**

**See Safe Use Instruction Form 1004**



# Wallace Thrifty Gantry Cranes

## Operating, Adjustment, and Inspection Instructions

*Read, Understand, and Comply with all instructions supplied with this crane. Also, pay attention to the equipment used with this crane such as hoists, trolleys, power drives (if applicable), etc.*

*Read, Understand, and Comply with the requirements of OSHA (Occupational Safety, and Health Administration) 1910.179*

### Inspect Crane Before Moving and/Or Each Day's Use

- Center Load under I-Beam before lifting
- When moving crane under load, position load at center of the I-Beam.
- Use crane at lowest height possible, to lower center of gravity.
- DO NOT lift or support humans.
- DO NOT allow load to swing or roll against any supporting members.
- DO NOT TOW or Pull Crane.
- DO NOT OVERLOAD CRANE.
  - A. Do not lift loads that are heavier than the rated capacity of the crane.
  - B. Make certain the load is free to be lifted.

### Positioning of Crane to Handle Loads

**DO**

7.5° | 7.5°

- Keep Load Hook of Hoist in the Shaded Safe Zone.

**Allowable**

- The design allows 7.5° movement to either side to allow for slight off-center loading.
- Under normal conditions (for example, the casters positioned at right angles to the I-Beam and the crane is free to roll), the crane will move to self-align over the load.

**DO NOT!**

- The crane may "topple" if the hook is not kept in the shaded safe load zone and the crane is not free to align over the load.
- Lifting off centerline at one end of the crane is dangerous! Up to 90% of the load can be carried by ONE leg. Even though rated capacity is not exceeded, the result can be a 90% overload and the trolley is improperly loaded.

### Positioning of Casters

- To secure crane position while lifting load, lock diagonally opposite casters as shown.
- To utilize maximum crane strength, lock casters as shown.
- To move crane and/or load perpendicular to I-beam, lock casters as shown or allow casters to pivot freely.
- To move crane and/or load parallel to I-beam, lock casters as shown or allow casters to pivot freely.

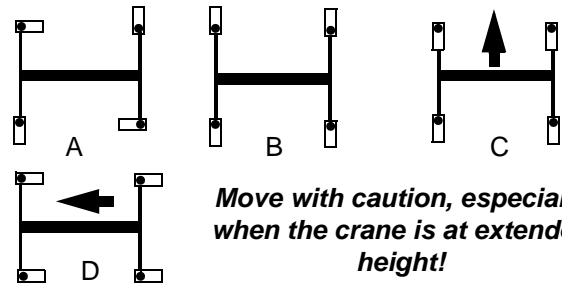

**Pull out and turn pin as necessary to provide a locked or unlocked caster position, then release pin.**

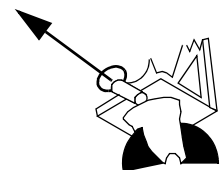

# Wallace Thrifty Gantry Cranes

## General Safety Instructions for Crane Adjustments and Use

- **Adjustments** and/or repairs should be made in an area where they will have the least interference with ongoing operations.
- **Do Not** make adjustments when the crane is under load. If crane is in operation, lower and disconnect the load before making any adjustments.
- **Secure Trolley and Hoist** to prevent movement during adjustment of crane.
- **Do Not Adjust** any one leg (or end) more than one foot above or below the other legs (or end), as it could cause the crane to “topple” and result in injury and/or equipment damage.
- **Rated load** capacity is plainly marked on each side of I-beam. Each hoisting unit shall have its rated load clearly marked and shall be legible from ground or floor.
- **Form 1004** (This Form) attached in convenient location by user.
- **Caution tag** attached to locking pins.
- **Make certain** that all Warning or Caution labels are in place and legible. Replacements for damaged or missing labels upon request.

## Methods of Supporting Crane for Assembly

**DO NOT ASSEMBLE OR DISASSEMBLE OR MAKE ANY ADJUSTMENTS TO CRANE**  
**UNTIL** the unit is supported by one of the three methods illustrated below.

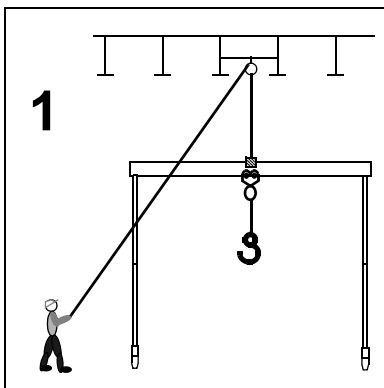

1 Use a Block and Tackle with cable winch with lifting bracket or beam clamp

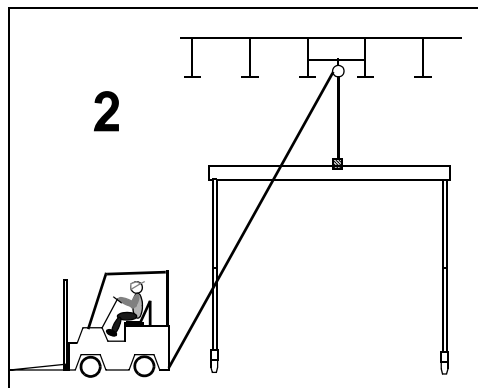

2 Use a block and tackle with lifting bracket or beam clamp with a suitable truck.

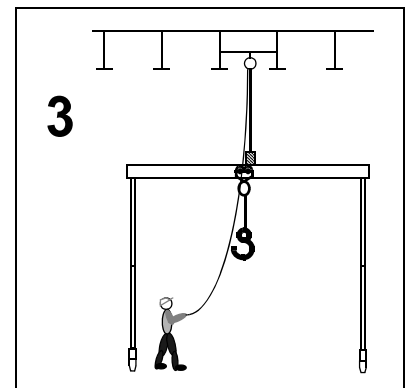

3 Use a hand or electric hoist with a lifting bracket or beam clamp.



# Wallace Crane Safety

## Safe Use and Operation Instructions & Inspection Checklist

*Read, Understand, and Comply with all instructions supplied with this crane. Also, pay attention to the equipment used with this crane such as hoists, trolleys, power drives (if applicable), etc. Read, Understand, and Comply with the requirements of OSHA (Occupational Safety, and Health Administration) 1910.179*

To ensure the safe operation of your Gantry, frequently inspect it for BENT, BROKEN, CORRODED, CRACKED, DAMAGED, or MISSING parts. DO NOT USE GANTRY if it does not meet inspection requirements. Please contact Wallace for replacements for any non-functional components.

### DO NOT:

- Overload Gantry
- Lift loads greater than the rated capacity.
- Make any adjustments when the Gantry is under load. If necessary to adjust the Gantry, first lower and disconnect the load.
- Lift or support humans.
- Allow the load to swing or roll against any supporting members.
- Tow or Pull Gantry.

### DO:

- Make certain the load is not attached to the floor.
- Remove any obstacles that may impede lifting.
- Make adjustments and/or repairs in an area where these operations will have the least impact on the normal operating environment.
- Secure the trolley and hoist to prevent movement during adjustment of the Gantry.
- Position the load at the center of the I-Beam when moving the Gantry under load.
- Use the Gantry at the lowest height possible.

### Disclaimer

Please note these instructions were derived from company proprietary materials and (3) source documents including **ANSI B30.17**, **CMAA Specification #74, Revised 1987**, and **OSHA 1910.179**. As excerpts, the short form Wallace documents are intended to serve as general guidelines and are not to be considered the sole source when performing routine maintenance and inspection tasks.

### Inspection Checklist on Other Side



# Inspection Checklists

Excerpted from ANSI B30.17 –1980

Chapter 17-2 Inspection, Testing, and Maintenance.

## Frequent Inspection

- a. Normal service, monthly.
- b. Heavy service, weekly to monthly.
- c. Severe service, daily to weekly.

## Periodic Inspection

- a. Normal service, yearly – done in place.
- b. Heavy service, yearly – done in place unless disassembly is indicated (*if you completely disassemble, you must retest*) emphasis WCC.
- c. Severe Service, quarterly – done in place.
- d. Recommended interval as suggested by manufacturer.

## Frequent Inspection Checklist

Any deficiencies as listed below shall be examined to determine if they constitute a hazard.

- All functional operating mechanisms for mis-adjustment interfering with proper operations.
- All limit switches should be checked without a load on the hook.
- Lines, tanks, valves, pumps and other parts of the pneumatic system for leakage.
- Hoists as specified in ANSI B30.16-1973

## Periodic Inspection Checklist

The crane should be examined to determine if any of the following defects exists. DO NOT USE if any damage is found.

- Deformed, cracked, or corroded structural members
- Loose bolts or rivets.
- Cracked or worn sheaves and drums.
- Worn, cracked or distorted parts, such as pins, bearings, wheels, shafts, gears, rollers, locking and clamping devices, bumpers, switch baffles, interlock bolts, and trolley stops.
- Excessive wear on brake system parts.
- Excessive wear of chain drive sprockets and excessive chain stretch.

