



Wallace Fixed Height Gantry Cranes

Hippolift Assembly Instructions

For any additional information, Please call 1-800-553-LIFT.

CAUTIONS

1. Read and understand instructions before using this gantry.
2. Inspect gantry thoroughly before using (see Form 379) for damaged or missing parts.
3. Do not lift more than rated capacity.
4. Center hoist over the load.
5. Do not allow load to swing or to roll against any supporting members.
6. When moving gantry under load, push on the gantry, not the load. Be certain that rolling surface is hard, level, clean and smooth.
7. Do not move gantry over 50 feet per minute (1/2 mph).
8. Not to be used for lifting or supporting humans.

Before You Begin

- Select a clear area to assemble the Crane. The work envelope should extend five feet beyond twice the leg length (when flat) and the length of the I-beam
- This clear area should be serviced by two overhead hoists or alternate as shown in Form 379. The cranes will raise the I-beam and leg assemblies when required.
- Select tools for fastening the nuts and bolts. You will also need: C-clamps to hold the trolley in place while the crane is assembled.
- Place parts on a flat surface, preferably on cardboard, to keep small parts clean and organized.

Before Placing the Gantry Under Load

- A. Make certain all hardware is securely attached and all locking pins are in place.
- B. Give the enclosed "Operating and Safety Instructions" to the person(s) with responsibility for the safe use of the Gantry.

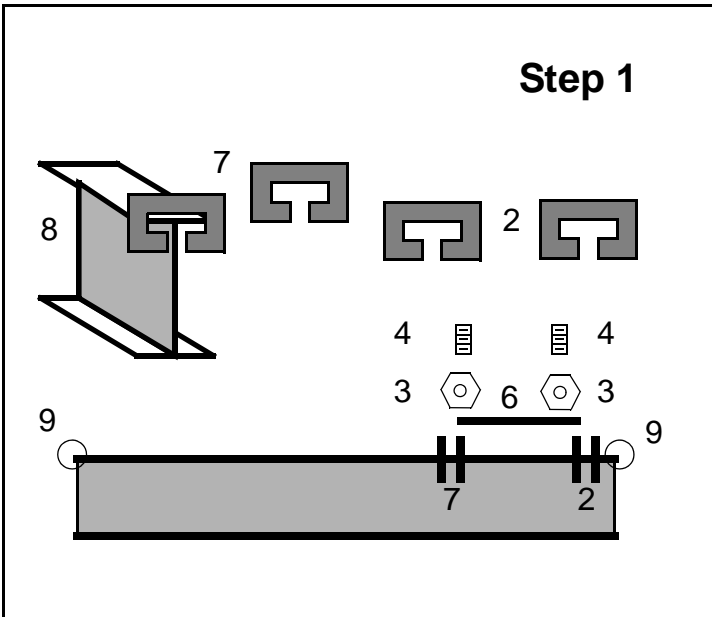

Step 1. Attaching the I-Beam Fittings to the I-Beam

- A. For assembly, select a lifting device (for example, an overhead crane, boom crane) able to lift the entire weight of the gantry crane model being assembled.
- B. Place **I-beam** (Item 8) upright on suitable supports so stenciling is right side up.
- C. Slide the **brace leg brackets** (Item 7), then the **main leg brackets** (Item 2), on the I-beam (Item 8). Be sure all brackets are aligned as shown on the Parts Location diagram.
- D. Attach the **spacer bar** (Item 6) to the **main leg bracket** (Item 2) and **brace leg bracket** (Item 7) as shown using the **set screws** (Item 4) and **nuts** (Item 3).

- NOTE:** Do not tighten set screws (Item 4) until after installing the main legs and brace legs as in Step 3.
- E. Position bracket assemblies on **I-Beam** (Item 8) for desired span.
 - F. Insert **key ring** (Item 9) without caution tag in holes at both ends of **I-Beam** (Item 8).

Step 2. Attaching the Trolley Stops and Trolley

- A. Install two **trolley stop angles** (13) at one end of **I-Beam** using **bolts** (14) **lock washers** (11) and **hex nuts** (12).
- B. Install trolley on end of **I-beam** (Item 8) without the **trolley stops** (Item 13).

CAUTION: Make sure trolley is adjusted for I-beam size with the manufacturer's recommendation on washer counts for each side.

- C. Install two **trolley stop angles** (Item 13) at the other end of the beam using the **bolts** (Item 14), **washers** (Item 11) and **nuts** (Item 12). For both trolley stops, tighten each nut and bolt to 200 ft./lb. of torque.

CAUTION: Secure trolley in the center of the I-Beam (Item 8), with suitable means, such as heavy clamps, when raising or lowering the assembly. Failure to do so may result in injury or death.

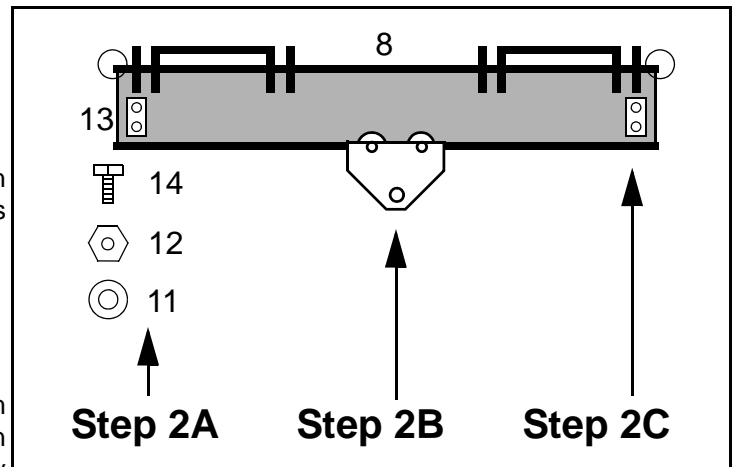

For any additional information, Please call 1-800-553-LIFT.

Step 3. Attaching Main Legs and Brace Legs to I-beam

- Place upper end of **main leg** (Item 16) between **main leg brackets** (Item 2) as shown and install pin (Item 1) and key ring (Item 9) with **caution tag** to secure main leg. The **main leg** (Item 16) must be placed so that brace leg support (as indicated on the Parts Location diagram) is facing towards the brace leg brackets (Item 7).
- Place **brace leg** (Item 15) in the brace leg support on the main leg (Item 16) and fasten in place with the **pin** (Item 17) and **key ring** (Item 9) with **caution tag** as shown. Brace leg must be oriented so that the hole in the upper end is parallel with **I-beam** (Item 8).
- The brace leg can now be installed between the **brace leg brackets** (Item 7). Install using the **pin** (Item 5) and **key ring** (Item 9) with caution tag.
- Tighten all set screws (Item 4) to securely lock brackets in place on the I-beam (Item 8).

NOTE: Be sure the Spacer is NOT bowed.

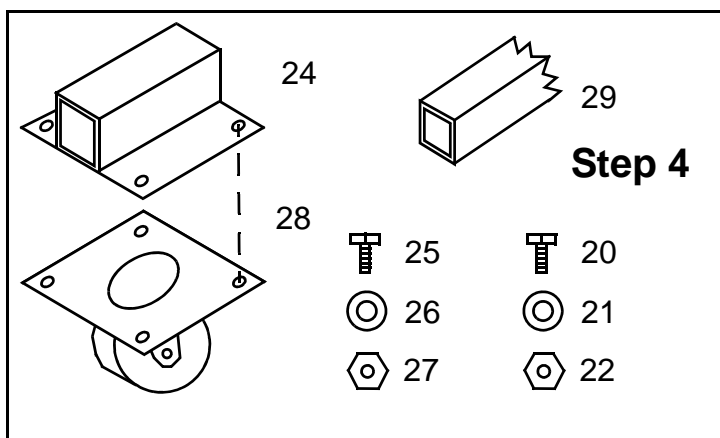
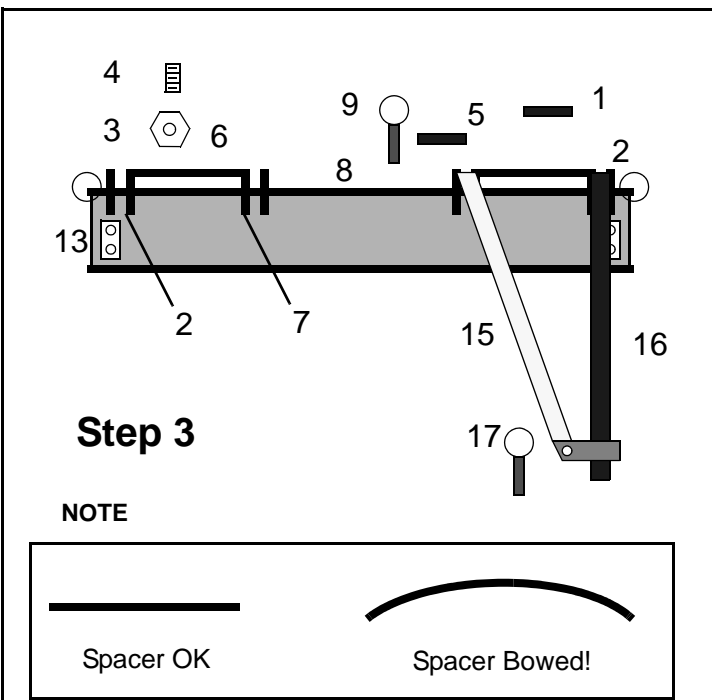

Step 4. Caster Frame Assembly

- Assemble **casters** (Item 28) to **caster plate** (Item 24) with **bolts** (Item 25), **lock washers** (Item 26) and **nuts** (Item 27). Tighten nuts and bolts to 57 ft/lb. of torque.
- Connect assemblies (Left) to **caster frame** (Item 29) using **bolt** (Item 20), **lock washer** (Item 21) and **nuts** (Item 22). Tighten nuts and bolts to 57 ft/lb. of torque.

Step 5. Assembly of Main Legs to Caster Frame

- Raise the **I-beam** (Item 8) with an approved lifting device until the distance between the bottom of the **main legs** (Item 16) is approximately the same as the length of the **caster frame tube** (Item 29).
- Attach **main legs** (Item 16) to **caster frame tubes** (Item 29) using **pin** (Item 23). Secure pins with **key ring** (Item 9) with caution tag.
- Recheck to make certain all locking devices (nuts, cotter pins, locking rings, etc.) are in place and secured.
- Lower the Gantry to the floor

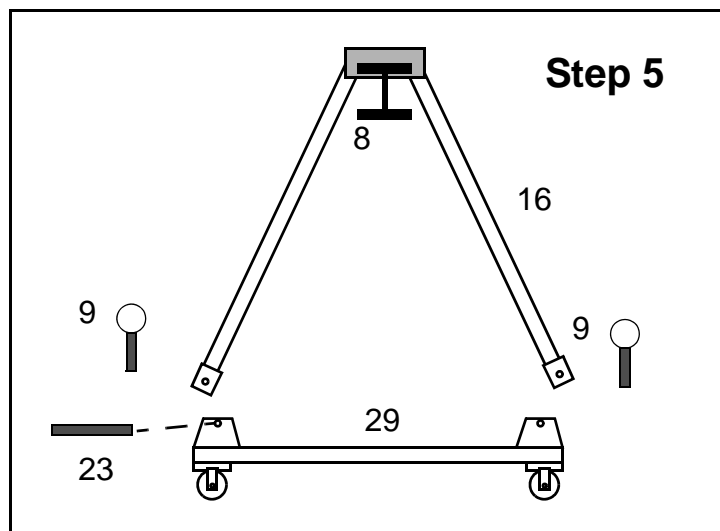

Read Form 379 and Form 504 prior to use.



Wallace Tri-Adjustable Gantry Cranes

Operating, Adjustment, and Inspection Instructions

Read, Understand, and Comply with all instructions supplied with this crane. Also, pay attention to the equipment used with this crane such as hoists, trolleys, power drives (if applicable), etc.

Read, Understand, and Comply with the requirements of OSHA (Occupational Safety, and Health Administration) 1910.179

Assembly and Safety Instructions

Inspect Crane Before Moving and/Or Each Day's Use

- Center Load under I-Beam before lifting
- When moving crane under load, position load at center of the I-Beam.
- Use crane at lowest height possible, to lower center of gravity.
- DO NOT lift or support humans.
- DO NOT allow load to swing or roll against any supporting members.
- DO NOT TOW or Pull Crane.
- DO NOT OVERLOAD CRANE.
 - Do not lift loads that are heavier than the rated capacity of the crane.
 - Make certain the load is free to be lifted.

Positioning of Crane to Handle Loads

DO

- Keep Load Hook of Hoist in the Shaded Safe Zone.

Allowable

The hinged suspension of the I-Beam allows 7.5° movement to either side to allow for slight off-center loading.

Under normal conditions (for example, the casters positioned at right angles to the I-Beam and the crane is free to roll), the crane will move to self-align over the load.

DO NOT!

- The crane may "topple" if the hook is not kept in the shaded safe load zone and the crane is not free to align over the load.
- Lifting off centerline at one end of the crane is dangerous! Up to 90% of the load can be carried by ONE leg. Even though rated capacity is not exceeded, the result can be a 90% overload and the trolley is improperly loaded

Positioning of Casters

- To secure crane position while lifting load, lock diagonally opposite casters as shown.
- To utilize maximum crane strength, lock casters as shown.
- To move crane and/or load perpendicular to I-beam, lock casters as shown or allow casters to pivot freely.
- To move crane and/or load parallel to I-beam, lock casters as shown or allow casters to pivot freely.

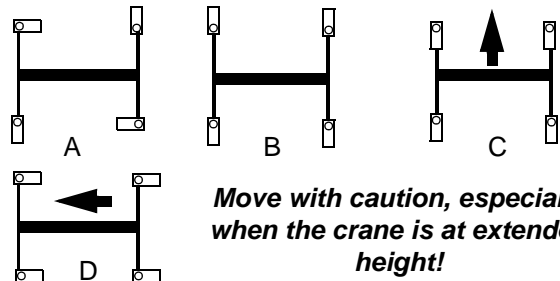

Pull out and turn pin as necessary to provide a locked or unlocked caster position, then release pin.

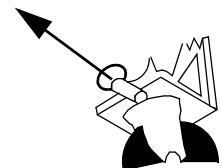

Wallace Tri-Adjustable Gantry Cranes

Height Adjustment Procedure

1. Lock casters parallel to the I-beam to prevent the main support legs from moving during adjustment.
2. Locate safety stop pins, as required during adjustment. See instructions on Tag #1337 attached to safety stop pin.
3. Raise crane slightly to clear notches in load bolts, pull out load bolts and rotate 90° to "lock-out" position.
4. When within approximately 3" of desired height, rotate load bolts to "unlocked" position.
5. Continue height adjustment (up or down), to allow load bolts to align with and engage next hole.
6. Visually check to insure that all four load bolt caps are FULLY ENGAGED.
7. Insert safety stop pins with Tag #1337 into first hole below upper main legs and secure in place with locking pins. When crane is at minimum height, attach to brace leg, as shown in Illustration "A".
8. Remove crane supports, trolley and hoist stops, and adjust caster positions as required.

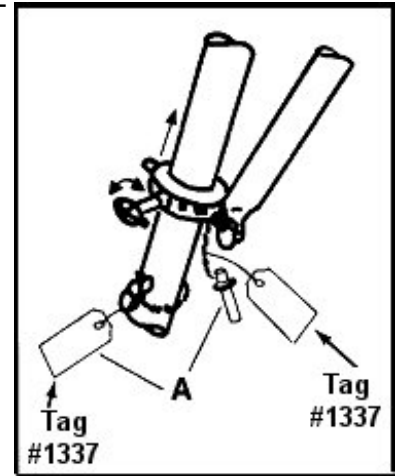

Caster Frame Adjustment Procedure

1. When I-beam is supported externally, raise I-beam slightly to take the weight off the caster frame spread adjustment pin. Remove pin. Raise or lower I-beam to decrease/increase caster frame spread. Replace spread adjustment pins. Secure in place using locking pins.

OR

2. a) Turn and lock casters perpendicular to the I-beam and secure trolley and hoist to prevent rolling. b) One jack (right or left) only is used for caster frame spread adjustment. c) Remove the pulley at the bottom of jack and pass end of cable through the pulley slot and extend it to the first hole in main leg above the caster frame using eye bolt provided, reinstall pulley, axle and klik-pins. d) Insert pin assembly and jack into first hole above the caster frame; attach all the locking pins in the pin assembly. e) Using jack winch, take weight off caster frame adjusting pin, then remove pin. f) Adjust spread as required and replace adjusting pins. Secure using locking pins.

OR

3. When lever type winch is used, take weight off spread adjustment pin, then remove pin. Adjust spread as required and replace spread adjustment pins. Secure in place using locking pins.

NOTE Be prepared to control the weight. The caster frame tends to open to maximum spread when the spread adjustment pins are removed.

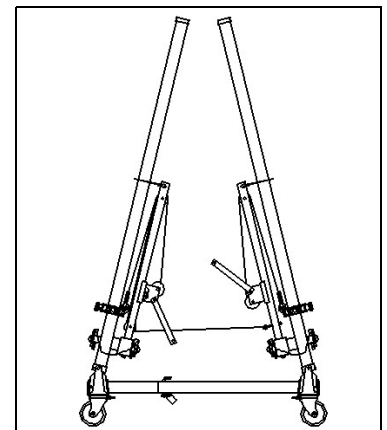

Cantilever Configuration/Adjustment of Distance Between Legs Along Length of I-Beam Procedure

1. Raise one end of I-beam until casters are off the floor.
2. Loosen set screws on top of I-beam hardware.
3. Slide I-beam hardware, with legs attached, on I-beam until the desired amount of cantilever or leg adjustment is achieved.
4. When adjusting for cantilever, DO NOT OVER-ADJUST. Adhere to distances specified in Form 123 (Cantilever Chart provided with the crane) for the amount of cantilever, load and counterweight required.
5. When desired amount of cantilever or leg adjustment is achieved, securely tighten set screws to prevent movement.
6. Repeat above if leg adjustment on opposite end is required.

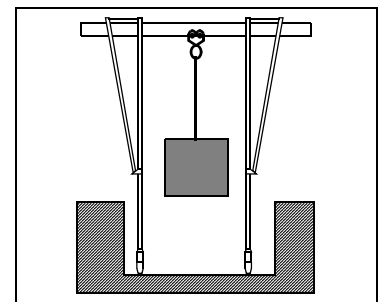

Wallace Cranes, Built-in Safety

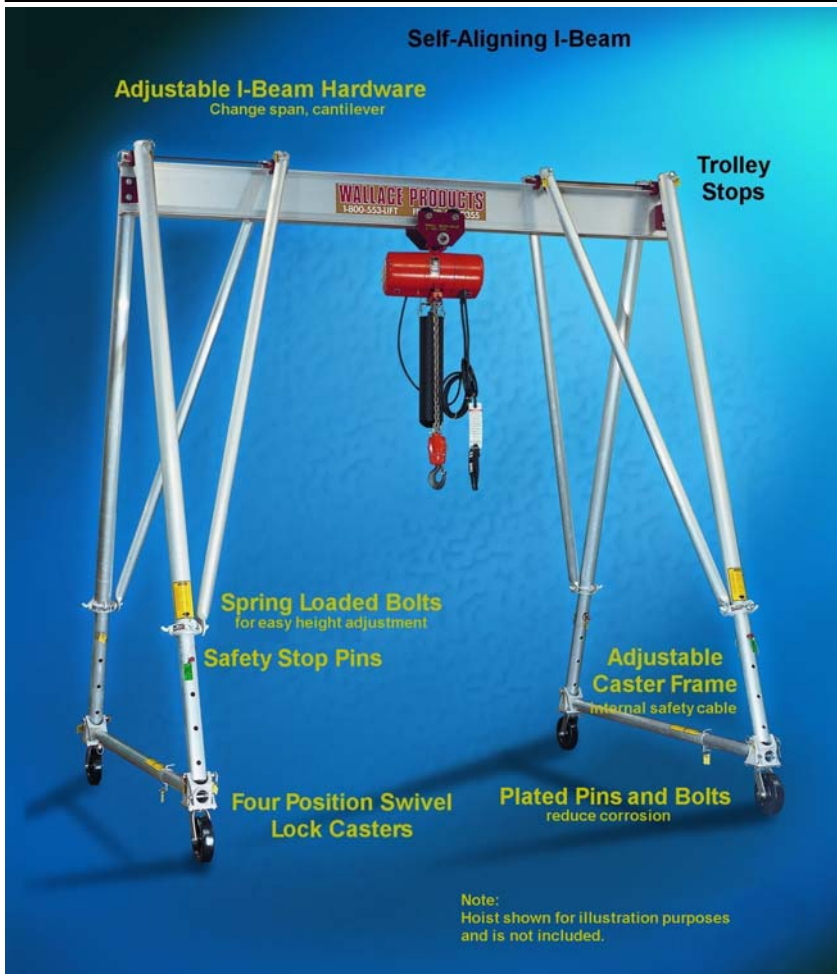

Wallace Tri-Adjustable Visual Check Points

To ensure the safe operation of your crane, inspect it for bent, broken, worn, corroded, cracked, or missing parts. A series of vital checkpoints are described and shown below. Check these areas closely to ensure that all pins and fastening hardware are in place and securely attached. Caution Tags are attached to the Locking Rings and Locking Pins in these critical areas to aid in your inspection. **DO NOT USE** the crane if it does not meet these and the relevant ANSI B30.17 inspection requirements.

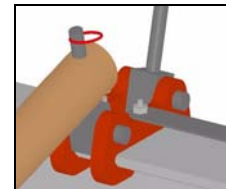

1. Brace legs are attached to pin assemblies and secured with locking rings. On round tube models (shown above) the flat end of the brace leg is attached to the load bolt casting. Also be sure that load bolt is properly engaged. See number 3.

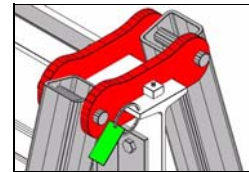

2. The main legs are attached to the pin assemblies and secured with locking rings. Locking rings at each end of the I-Beam should be in place and secured to ensure the I-Beam Hardware never slides beyond end of I-Beam.

3. The four safety stop pins must be installed and secured with klik pins in the first hole below the load bolt (see crane image, left). When crane is at minimum height, attach pins to brace leg.

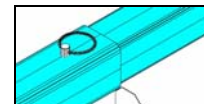

4. The caster frame spread pins should be secured with klik pins.

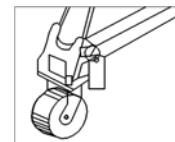

5. Lower main legs are attached to the caster frame casting with pins, secured with a klik pin. Inspect casters and wheels for damage, such as cracks, bent king pins and freedom of movement. Replace any damaged casters immediately.

Read, Understand, and Comply with the instructions on the Crane and:

- Rated load clearly stenciled on opposite sides of I-beam.
- Form 379 (This Form) attached in convenient location by user.
- Caution label for instructions attached to caster frames.
- Caution label pointing to caster frame adjustment pin.
- Caution labels attached to main legs.
- Caution tag attached to safety stops.
- Caution tag attached to locking pins.

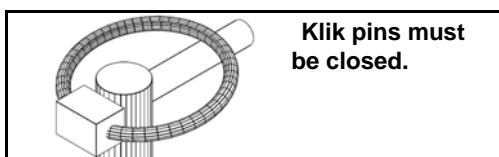

CAUTION AREAS

Make certain that all **CAUTION** labels are in place and legible. Replacements for damaged or missing labels upon request.

Inspect that rated capacity is plainly marked on each side of I-beam. Each hoisting unit shall have its rated load clearly marked and shall be legible from ground or floor.

Inspect safety cables in caster frames for proper attachment, fraying or any damage. Replace damaged cables immediately.

Wallace Cranes
71 N Bacton Hill Rd.
Malvern, PA 19355



www.wallacecranes.com
800-553-LIFT

© 2008 All rights reserved.

Wallace Tri-Adjustable Cranes

General Safety Instructions for Crane Adjustments

- **ADJUSTMENTS** and/or repairs should be made in an area where they will have the least interference with ongoing operations.
- **DO NOT** make adjustments when the crane is under load. If crane is in operation, lower and disconnect the load before making any adjustments.
- **SECURE TROLLEY AND HOIST** to prevent movement during adjustment of crane.
- **EXTEND CASTER FRAMES** to maximum width (last hole) when possible, for greatest stability.
- **SAFETY STOP PINS** should be installed in the first hole below the load bolt on the main legs.
- **DO NOT ADJUST** any one leg (or end) more than one foot above or below the other legs (or end), as it could cause the crane to “topple” and result in injury and/or equipment damage.

Methods of Supporting Crane for Assembly

DO NOT ASSEMBLE OR DISASSEMBLE OR MAKE ANY ADJUSTMENTS TO CRANE
UNTIL the unit is supported by one of the five methods illustrated below.

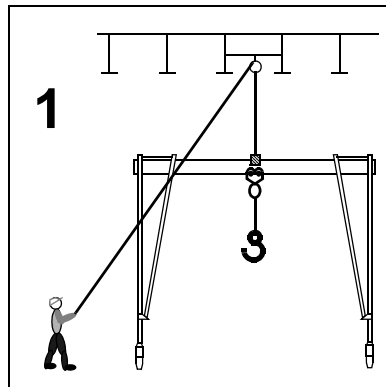

1 Use a Block and Tackle with cable winch with lifting bracket or beam clamp

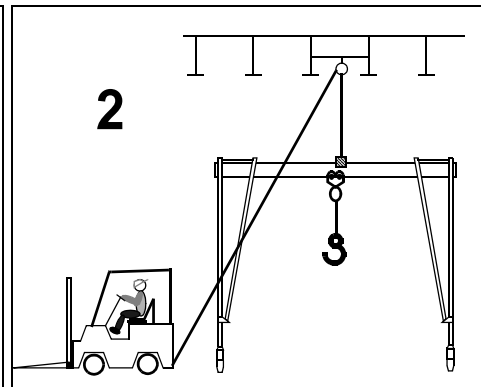

2 Use a block and tackle with lifting bracket or beam clamp with a suitable truck.

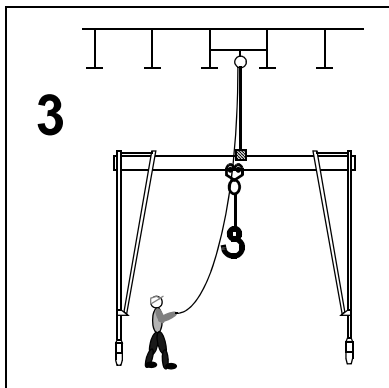

3 Use a hand or electric hoist with a lifting bracket or beam clamp.

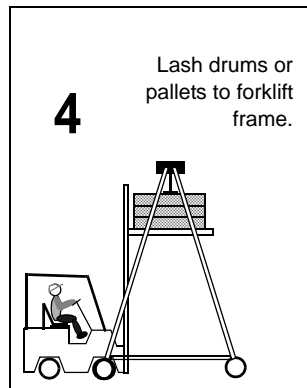

4 Use a forklift truck.

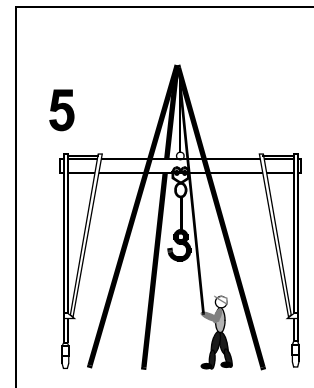

5 Use a tripod and hoist with a lifting bracket or beam clamp.

