



# Wallace Adjustable Gantry Cranes

## Thrifty Assembly Instructions

Read, Understand, and Comply with all instructions supplied with this crane. Also, pay attention to the equipment used with this crane such as hoists, trolleys, power drives (if applicable), etc. Read, Understand, and Comply with the requirements of OSHA (Occupational Safety, and Health Administration) 1910.179

### Parts List

Item	Description
1	Post
2	Frame Assembly -- Left
3	Frame Assembly -- Right
4	Pin -- Height Adjustment
5	Spring -- Height Adjustment
6	Spring -- Pin
7	Upper Bolt Plate
8	Lower Bolt Plate
9	Stabilizer Plate
10	Cap Screw -- Caster
11	Lock Washer (Internal Tooth) Caster
12	Hex Nut -- Caster
13	Caster
14	Swivel Lock -- Caster
15	Cap Screw -- Lower Bolt Plate
16	Lock Washer -- Split
17	Hex Nut -- Lower Bolt Plate
18	Cap Screw -- Upper Bolt Plate
19	Lock Washer -- Split
20	Hex Nut -- Upper Bolt Plate
21	Cap Screw
22	Bevel Washer
23	Lock Washer
24	Hex Nut
25	I- Beam

### CAUTION AREAS

Make sure that all **CAUTION** labels are in place and legible. Inspect that rated capacity is plainly marked on each side of I-Beam. Each hoisting unit shall have its rated load clearly marked and legible from ground or floor.

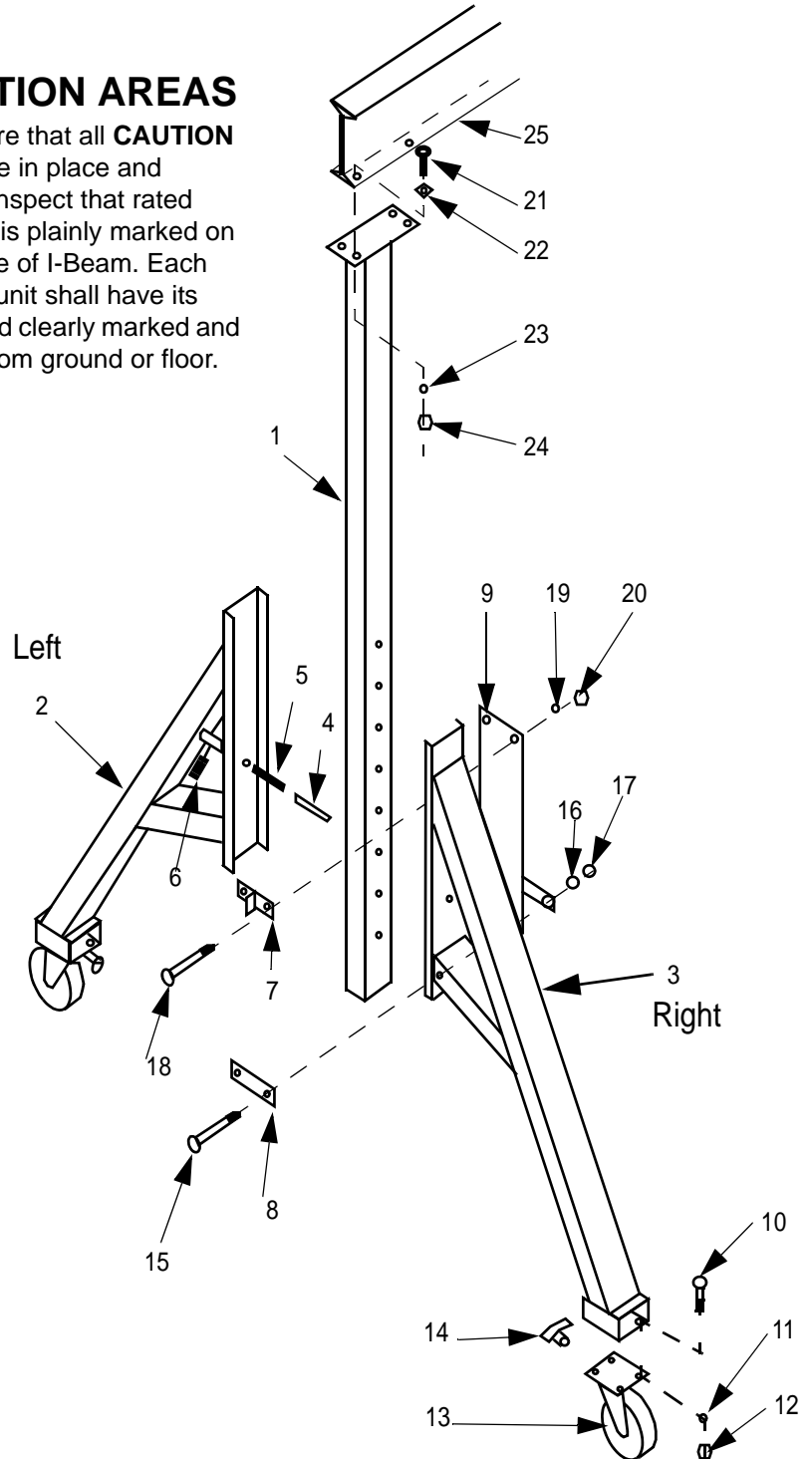

### Before you Begin

- Clear an open area at least as large as 2 X the leg length and wider than the beam.
- Get a crane or lifting device capable of lifting the entire weight of the completed crane.
- Assemble a work crew of no less than three. One will operate the lifting crane and the others perform the assembly. You may need more to lift the higher capacity legs.

See Safe Use Instruction Form 1004

Wallace Cranes  
71 N Bacton Hill Rd.  
Malvern, PA 19355



www.wallacecranes.com  
800-553-LIFT

© 2008 All rights reserved.

# Assembly Instructions

For assembly, select an area with a safe lifting means. For easiest and safest assembly, use an area with two overhead hoists (for example an overhead crane) to raise the I beam when required.

## Step 1. Installing the Trolley (Sold Separately)

- Raise the I-Beam, using a safe lifting means, so stenciling is right-side up.
- Install Trolley from either end of the beam on the lower flange of the beam
- Lock Trolley in center of beam using C-Clamps on the bottom flange of the beam.

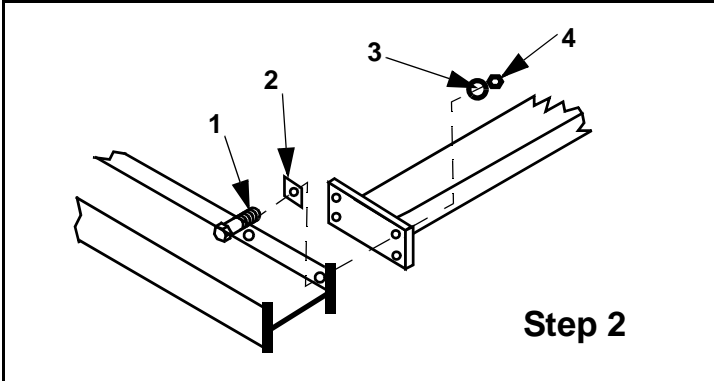

## Step 2. Attaching the Post to the I-Beam

- Place I-Beam web side down on minimum height supports approximately 4" - 24" above floor (i.e. wood planks) that provide enough clearance under beam for Trolley and lifting means being used.
- Align adapter plates of the posts with the applicable location of the I-Beam for attachment. (**NOTE:** Raise and support (such as wood planks) both ends of posts, as necessary). **NOTE:** If unit is equipped with adjust-a-span kit, disregard 2C through 2D and refer to adjust-a-span kit instructions.
- Insert cap screws (1) with bevel washers (2) through flange of I-Beam and adapter plates of the posts.
- Insert lock washers (3) and hex nuts (4) on cap screws (1) and tighten cap screws and hex nuts.

## Step 3. Attaching the Frames to the Posts

- Remove the cap screws, lock washers, hex nuts, upper bolt plate, lower bolt plate and stabilizer plate that hold the left hand frame and right hand frame together.
- Raise the I-Beam with posts attached, using a safe lifting means.
- Place left hand frame to post and align 3/4" diameter pin with hole in post. (**NOTE:** Raise or lower beam to adjust height of post as necessary) and insert pin through post.
- Place right hand frame to post, align the 3/4" diameter pin with hole in frame. Use a large C- clamp to hold both frames while attaching bolt to plates, stabilizer plate and hardware previously removed.
- Tighten all hardware and remove C-clamp.

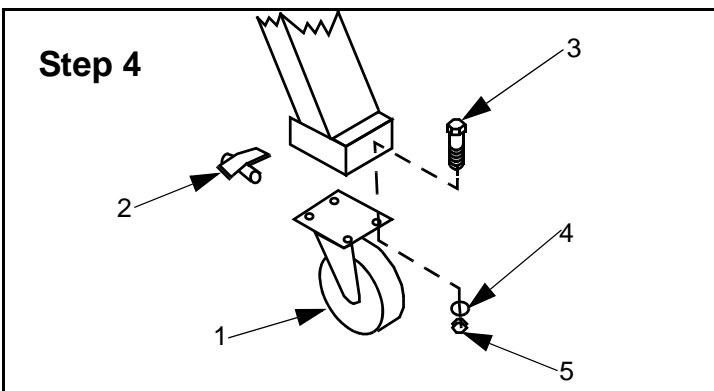
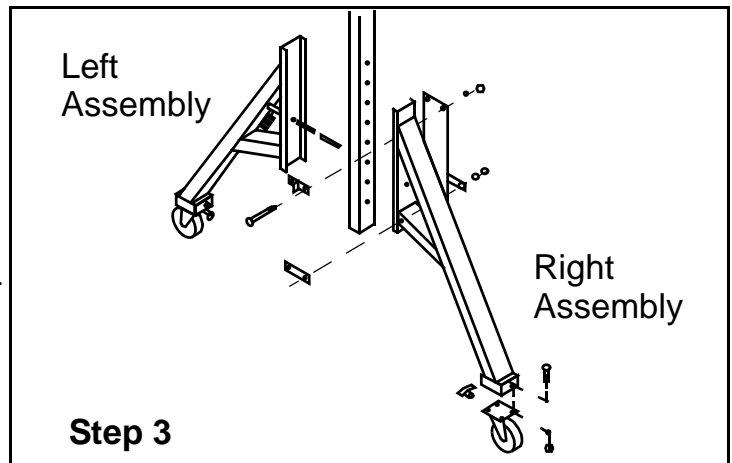

## Step 4. Attaching the Casters To the Frame Assemblies

- Raise the I-Beam, so that the frames are sufficiently above the floor for installation of the casters.
- Attach casters (1) and swivel locks (2) to the frame as shown, using cap screw (3), lock washer (4) and hex nut (5) provided. (**NOTE:** Some models have swivel locks welded to caster rigs).
- Lower gantry so that casters are on floor and remove lifting means. (**NOTE:** For track-mounted gantries - if frames/casters do not properly align with track, slightly loosen bolts that attach posts to frames and re-tighten).

## Step 5. Remove C-Clamps on Bottom Flange of Beam (to release Trolley)

**ALL BOLTS SHOULD BE TIGHTENED TO 25 FOOT POUNDS  
25 FOOT POUNDS = 300 INCH POUNDS**





# Wallace Thrifty Gantry Cranes

## Operating, Adjustment, and Inspection Instructions

*Read, Understand, and Comply with all instructions supplied with this crane. Also, pay attention to the equipment used with this crane such as hoists, trolleys, power drives (if applicable), etc.*

*Read, Understand, and Comply with the requirements of OSHA (Occupational Safety, and Health Administration) 1910.179*

### Inspect Crane Before Moving and/Or Each Day's Use

- Center Load under I-Beam before lifting
- When moving crane under load, position load at center of the I-Beam.
- Use crane at lowest height possible, to lower center of gravity.
- DO NOT lift or support humans.
- DO NOT allow load to swing or roll against any supporting members.
- DO NOT TOW or Pull Crane.
- DO NOT OVERLOAD CRANE.
  - Do not lift loads that are heavier than the rated capacity of the crane.
  - Make certain the load is free to be lifted.

### Positioning of Crane to Handle Loads

**DO**

7.5° | 7.5°

- Keep Load Hook of Hoist in the Shaded Safe Zone.

**Allowable**

- The design allows 7.5° movement to either side to allow for slight off-center loading.
- Under normal conditions (for example, the casters positioned at right angles to the I-Beam and the crane is free to roll), the crane will move to self-align over the load.

**DO NOT!**

- The crane may "topple" if the hook is not kept in the shaded safe load zone and the crane is not free to align over the load.
- Lifting off centerline at one end of the crane is dangerous! Up to 90% of the load can be carried by ONE leg. Even though rated capacity is not exceeded, the result can be a 90% overload and the trolley is improperly loaded.

### Positioning of Casters

- To secure crane position while lifting load, lock diagonally opposite casters as shown.
- To utilize maximum crane strength, lock casters as shown.
- To move crane and/or load perpendicular to I-beam, lock casters as shown or allow casters to pivot freely.
- To move crane and/or load parallel to I-beam, lock casters as shown or allow casters to pivot freely.

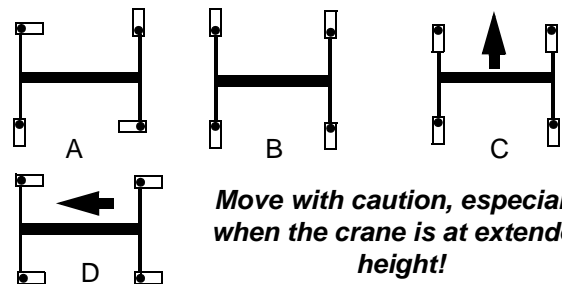

**Pull out and turn pin as necessary to provide a locked or unlocked caster position, then release pin.**

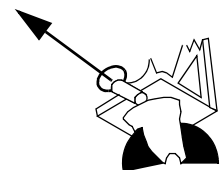

# Wallace Thrifty Gantry Cranes

## General Safety Instructions for Crane Adjustments and Use

- **Adjustments** and/or repairs should be made in an area where they will have the least interference with ongoing operations.
- **Do Not** make adjustments when the crane is under load. If crane is in operation, lower and disconnect the load before making any adjustments.
- **Secure Trolley and Hoist** to prevent movement during adjustment of crane.
- **Do Not Adjust** any one leg (or end) more than one foot above or below the other legs (or end), as it could cause the crane to “topple” and result in injury and/or equipment damage.
- **Rated load** capacity is plainly marked on each side of I-beam. Each hoisting unit shall have its rated load clearly marked and shall be legible from ground or floor.
- **Form 1004** (This Form) attached in convenient location by user.
- **Caution tag** attached to locking pins.
- **Make certain** that all Warning or Caution labels are in place and legible. Replacements for damaged or missing labels upon request.

## Methods of Supporting Crane for Assembly

**DO NOT ASSEMBLE OR DISASSEMBLE OR MAKE ANY ADJUSTMENTS TO CRANE**  
**UNTIL** the unit is supported by one of the three methods illustrated below.

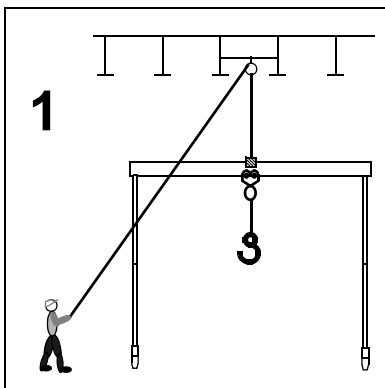

1 Use a Block and Tackle with cable winch with lifting bracket or beam clamp

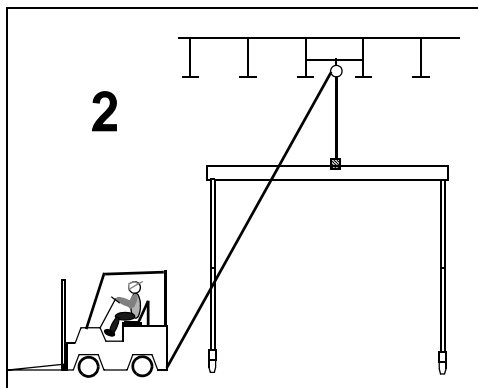

2 Use a block and tackle with lifting bracket or beam clamp with a suitable truck.

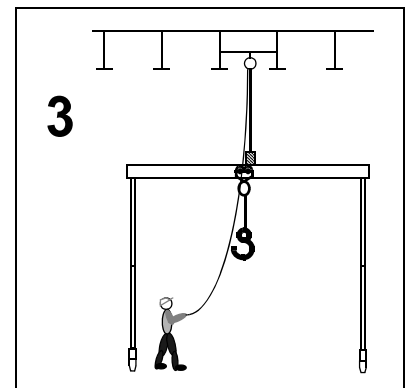

3 Use a hand or electric hoist with a lifting bracket or beam clamp.

